

# POWER BRAKE BOOSTER BRACKET Installation

*NOTE: INSTALLATION OF THE B.C. BRONCOS POWER BRAKE BOOSTER BRACKET SHOULD BE PERFORMED BY A CERTIFIED MECHANIC*

## BEFORE YOU BEGIN

Thoroughly read and understand the instructions before proceeding with the installation of the B.C. Broncos Power Brake Booster Bracket.

Brake function should be thoroughly checked and any problems corrected before the B.C. Broncos Power Brake Booster Bracket is installed. Conditions such as pulling under braking, one wheel lockup, premature rear wheel lockup, low or a soft pedal are indications of brake problems.

Premature rear wheel lockup can be corrected usually by installing an adjustable proportioning valve. These can be purchased at your local speed shop, through catalogs, on the Internet or through B.C. Broncos.

If you have changed the rubber master cylinder to brake differential valve lines with hard lines, it will be necessary to reshape these lines for the new proportioning valve. Take care not to kink, bend to sharp or break them. If you have any doubts about a brake line, replace it! Make sure that the hard lines DO NOT contact any other surface i.e. fender well, steering shaft, frame rail, etc. Touching any other surface will cause wear of the hard line and possible brake failure! It is highly recommended that the old rubber lines be changed to hard lines. They provide better brake feel by not swelling during braking. B.C. Broncos offers a precision bent hard line kit specifically designed for the B.C. Broncos Power Brake Booster Bracket conversion.

## TOOLS NEEDED

Ratchet and sockets  
Flared nut wrenches  
Rule  
Hack saw  
Pliers  
Shop rags

## ADDITIONAL ITEMS NEEDED

A vacuum port is required for the brake booster to operate. If your engine does not have a manifold vacuum port at the rear of the intake manifold, one will need to be installed.

## PROCEDURE

1. Measure the height of the brake pedal from the floor, as shown in figure 1, and record it here:

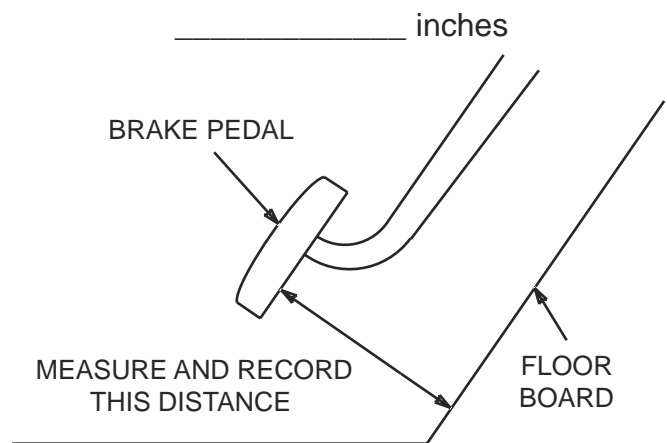
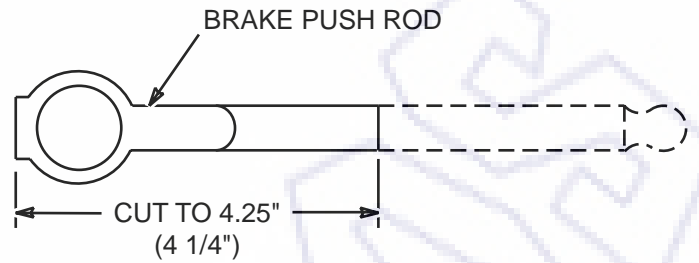

Figure 1

2. From under the dash, disconnect the master cylinder push rod and brake light switch from the brake pedal noting how it went together. Use only the factory-retaining clip when you reinstall the push rod and backup switch.
3. Open and support the hood.
4. Disconnect the brake lines from the master cylinder.
5. Remove the two bolts holding the master cylinder and remove the master cylinder. Replace the bolt on the right side (closest to the driver side fender) of the master cylinder and tighten to manufactures specs. The use of this bolt is not necessary for the installation of the B.C. Broncos Power Brake Booster Bracket. See Figure 2.



**Figure 3**

7. Install the rubber diaphragm seal over the brake rod clevis. Insert the assembly thru the hole on the fire wall side of the bracket assembly. With the small allen set screw facing down, attach the clevis to the bell crank using the clevis pin. The pin is to be installed with the button head at the top and the cotter pin hole at the bottom. Secure the clevis pin with the cotter pin making sure to wrap the legs of the pin around the clevis pin. See Figure 4.

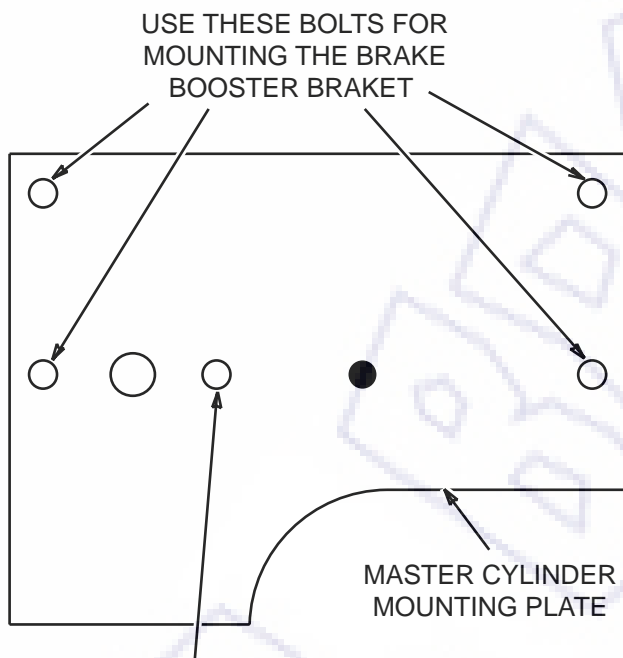

THIS MOUNTING BOLT IS NOT NEEDED TO MOUNT THE BOOSTER BRACKET. AFTER REMOVING THE OLD MASTER CYLINDER, REPLACE THIS BOLT AND TIGHTEN TO MANUFACTURES SPECS.

**Figure 2**

6. Carefully cut the original brake rod to an overall length of 4.25" (4 1/4") per Figure 3 (be sure and save the cutoff end). Insert the cut brake rod into the brake rod clevis provided in the kit.

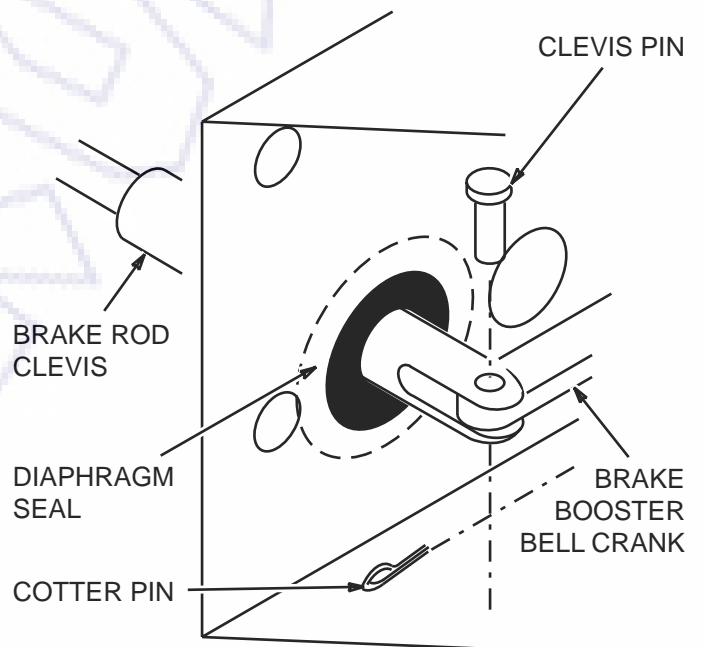

**Figure 4**

8. Remove the four firewall bolts shown in the Figure 2 and position the booster bracket on the firewall. Loosely thread the bolts thru the booster bracket and position the rubber diaphragm seal in the bracket opening between the booster bracket and fire wall.

9. Four screws hold the steering column boot to the firewall. The top two may interfere with the bottom of the brake bracket. If the brake bracket does not sit flush against the firewall, remove the top two screws.
10. Reassemble the brake rod/brake light switch using only the factory clip.
11. Make sure that the rubber diaphragm seal is centered in the bracket opening and tighten the four mount bolts to factory specs.
12. Reinstall the two screws removed in Step 9. In some cases, relocating these screws may be necessary. Drill the mounting holes slightly lower to clear bottom of brake bracket.
13. Using a master cylinder bench bleed kit, bleed the master cylinder. Make sure you use plenty of rags to catch any brake fluid that may leak or splash during the bleed.
14. If new hard lines are being installed, install them per the instruction sheet that came with the kit.
15. From inside the Bronco, apply the brakes and tighten (DONT OVER TIGHTEN) the brake rod set screw.

*WARNING: The setscrew is NOT an adjustment. Its intent is only to keep the brake rod from separating from the brake rod clevis. The brake rod must be fully bottomed out in the brake rod clevis before the setscrew is tightened!*

Check the height of the brake pedal, it should be the same height as you noted in Step 1. If necessary, remove the brake rod and shorten the brake rod as outlined in Step 6 or add a small piece of the cut portion of the brake rod to raise the pedal. See Figure 5.

*CAUTION: If the height of the brake pedal is higher than recorded in Step 1. The pedal must adjusted by trimming the brake rod in 1/8" increments only. Trimming too much at one time will greatly effect the height of the pedal.*

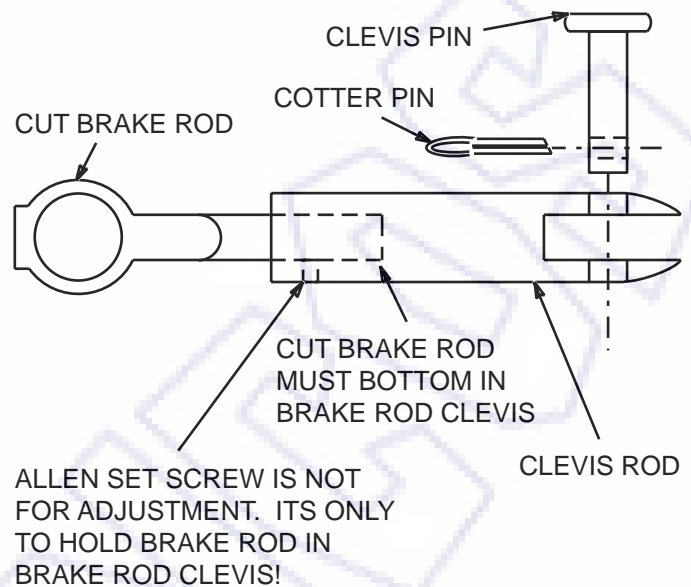

**Figure 5**

16. Install the brake booster vacuum hose to the brake booster and the manifold, routing it as not to interfere with brake booster bell crank, throttle linkage, etc.
17. Bleed the whole brake system. After bleeding, check that all bolts, nuts, pins, clips, cotter pins, flare nuts are tight.
18. Top off brake fluid, making sure the cap is seated properly. Check that the brake rod is free. Check that brake lights are working properly. If you have any doubts about the installation, DO NOT drive the Bronco until the braking system has been checked and is determined to be working properly.
19. Be VERY CAUTIOUS on the first test drive. Test the brakes thoroughly, test and retest again.
20. Recheck that all bolts, nuts, pins, clips, cotter pins, flare nuts are tight.

## HARD BRAKE LINES Installation

### BEFORE YOU BEGIN

**WARNING: DO NOT RE-BEND OR MODIFY THE LINES IN ANY WAY! BENDING OR MODIFYING MAY WEAKEN THE BRAKE LINE AND ARE BENT OR MODIFIED LINES ARE NOT RETURNABLE!**

Be sure you have the proper lines prior to installation. Body lifts require special length lines. If you have a body lift and did not inform B.C. Broncos when ordering, let us know and we will gladly exchange them with the proper length if they are not used or damaged.

Please note that the B.C. Broncos brake lines are precision bent and only slight adjustments will be necessary for proper fit. If tubing becomes kinked during any of these adjustments, DO NOT USE IT, but contact B.C. Broncos for a free replacement.

**WARNING: The brake tubing must not contact any other surface except the hold down clamp. Keep the tubing from contacting inner fender sheet metal, steering shaft, other tubing, etc. as contact and vibration will wear tubing, causing a leak and brake failure!**

Make sure the reservoir closest to the DRIVER (larger) supplies the front brakes and the reservoir (small) closest to the GRILL supplies the rear brakes.

### TOOLS NEEDED

Flare nut wrenches	Hammer
Drill Drill motor	5/16" drill bit
Center punch	Shop rags

### PROCEDURE

1. Clean the differential valve and master cylinder brake line flare nuts. You must keep dirt out of the brake system!
2. Brake fluid will remove paint so protect painted surfaces with shop rags prior to removing brake lines.
3. Remove the old brake lines.
4. Position the B.C Broncos lines between the steering shaft and the inner fender well.
5. Thread the flare nut into the differential valve first and hand tighten only. Do not remove nut /bolt from clamp prior to attaching to the differential valve!
6. Thread the flare nuts into the master cylinder.
7. Remove the nut and bolt from clamp.
8. Position the clamp(s) approx 2 1/2" from fender well crease (see illustration, page 2) and mark it using the center punch. You may not be able to get a drill into the space between the engine and the fender well so you must work from inside the fender well at this point.
9. From the inside of the fender well, locate the center punch dimple from Step 8 and re-punch it the opposite direction.
10. Drill the inner fender using the 5/16" drill to attach the brake line clamp.

*Caution: as you drill make sure the brake lines on the inner fender well are not in a position that they may be damaged from the drill.*

## Brake Lines Installation

11. Position the two clamps and insert the ¼" x 20 screw through each clamp and then through the inner fender well securing it with the nut on the wheel side of the fender well.
12. Check for any brake line interference as stated in the **'WARNING'** above.
13. Tighten each of the flare nuts using the proper size flare nut wrench.
14. Top off brake fluid in the master cylinder and bleed brakes.
15. Check for leaks and carefully test brake function.

