

## 1/8" ROCKSKIS Installation

**NOTE:** These procedures apply to the installation of B.C. Broncos 1/8" unpainted steel or stainless steel Rosckskis.

### TOOLS NEEDED

1/8", 3/16", 5/16" drill bits

Drill motor

Center punch

3/8" wrench

Large flat and phillips screw drivers

Awl

Hammer

Floor jack

2' long section of 2 X 4 lumber

### BEFORE YOU BEGIN

1. Make sure that the pinch weld flange at the bottom of the rocker panel is straight. (See figure 1)

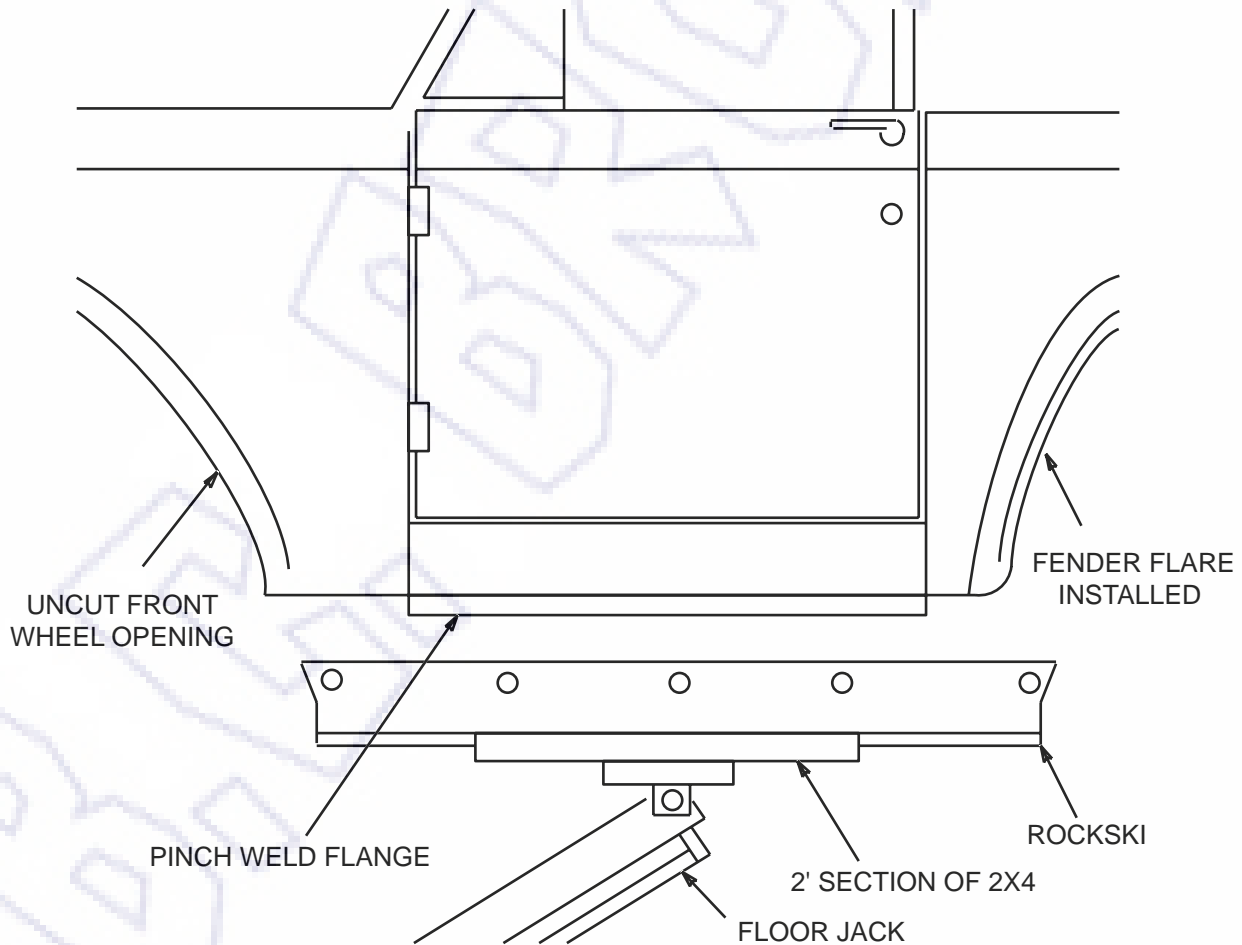

Figure 1

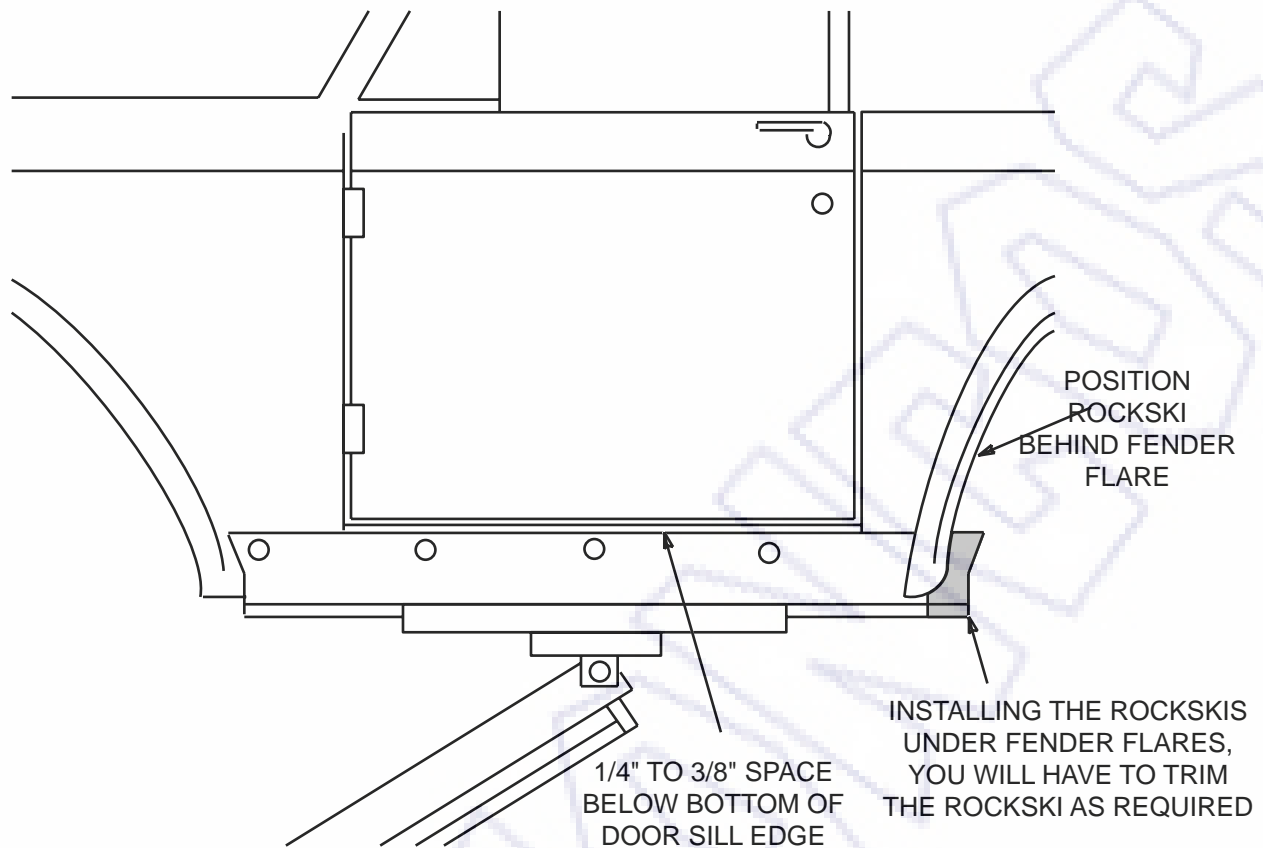

Figure 2

2. If you Bronco as fender flares, remove the bottom two pop rivets from the front and rear flares at the rocker panel.
3. Remove the front and rear fender support brackets as shown in Figure 3. (No longer needed)
4. For paintable Rockski sand, prime, and paint to suit. If installing onto a Bronco with cut rear fenders and fender flares, do not sand, prime and paint rockski until after trimming excess material in step #4.
2. Position the 2 X 4 on the wide flat area at the bottom of the Rockski. Position the jack under the 2 X 4 to hold the Rockski in position as shown in Figure 1.

PROCEDURE

1. Hold the Rockski up to the rocker panel and align the Rockski right and left, making sure that the notch in the inside nearest the front fender fits around the brace on the backside of the rocker panel pinch weld. Push the Rockski as far forward as the notch will allow as shown in Figure 4.

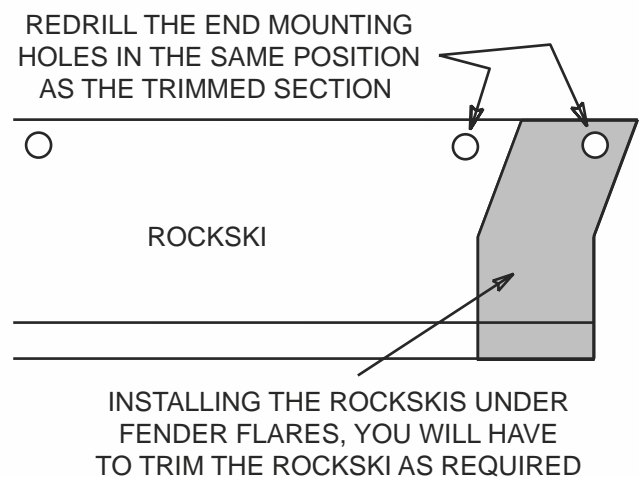
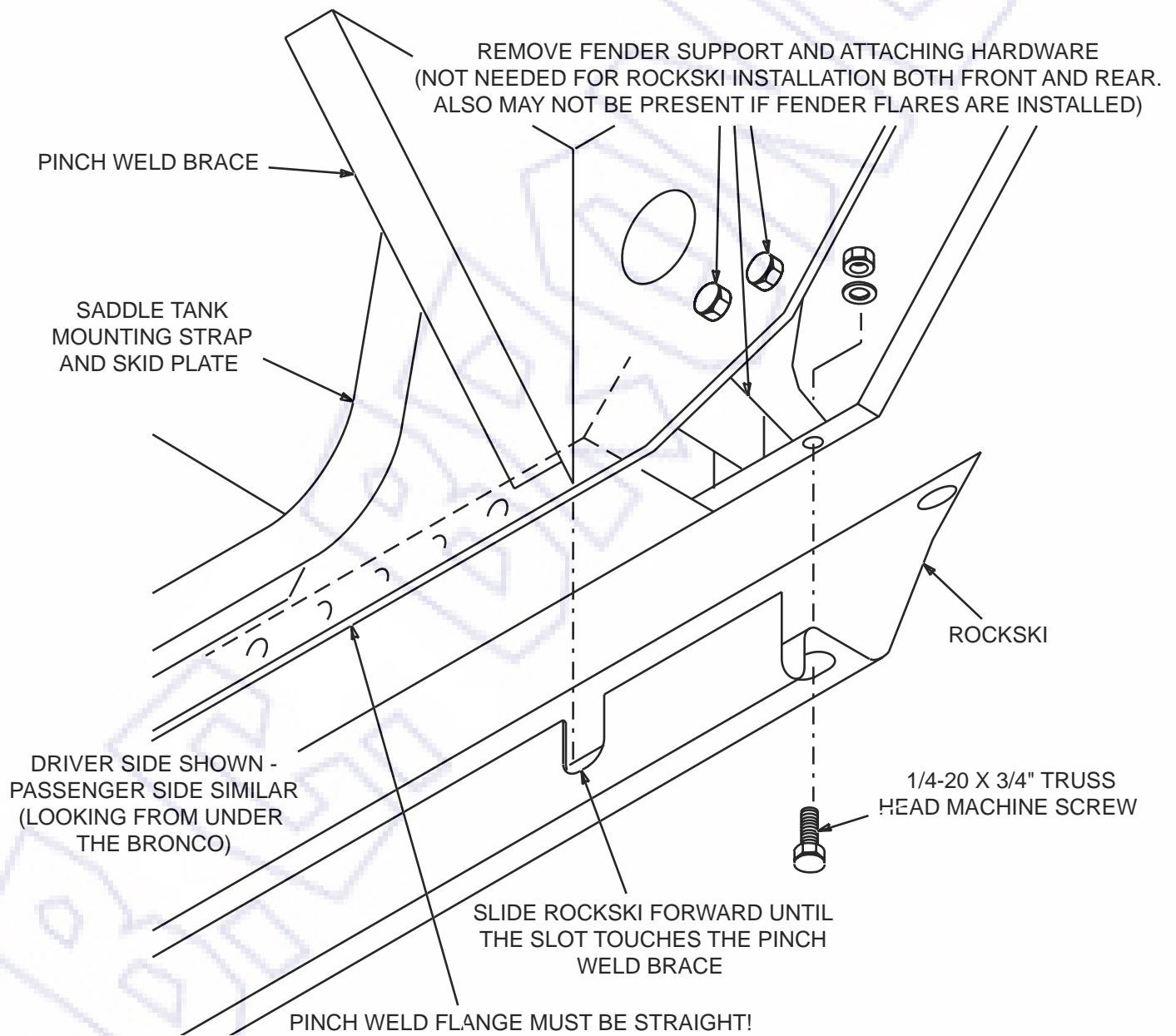

Figure 3

3. With the jack, raise the Rockski up between body and fender flare until it bottoms out and there is a 1/4" to 3/8" space below the bottom of the door. Watch for hang-ups, usually around the notch.
4. *NOTE: If installing Rockskis on a Bronco with uncut rear fenders, skip this step and proceed to step #5.*
  - a. With the Rockski firmly positioned, use a marker or scribe on the back side of the rockski to place a cut mark where excess material will be removed.
  - b. Lower jack and remove Rockski from Bronco.
  - c. Measure the position of the Rockski's rear-most bolt hole in relation to the top and end of the Rockski (this bolt hole will be removed with the trimmed material).



**Figure 4**

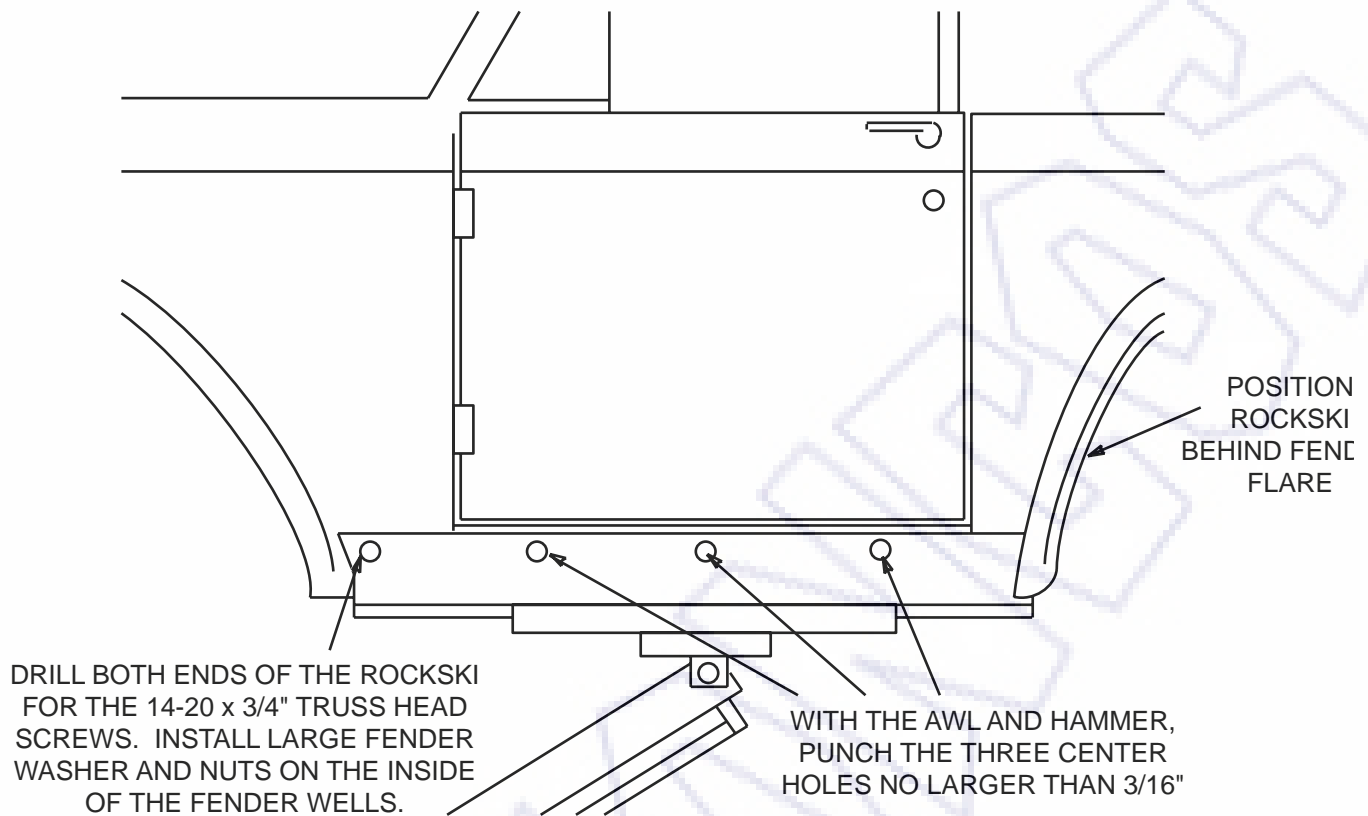

Figure 5

- d. Measure and use a punch to mark where the new bolt hole will be drilled, using the measurements of the original bolt hole, translated to be in relation to the new edge of the Rockski after excess material is removed (see Figure 3), and drill new hole with 5/16" bit.
  - e. Use a die grinder or similar tool to remove the excess material from the Rockski. Deburr and file or sand edge smooth.
  - f. Sand, primer and paint Rockski. Let paint dry.
  - g. Repeat steps 1-3 to re-position the trimmed Rockski and continue with the installation procedure.
5. Attach the Rockski using a 1/4-20 X 3/4" truss head machine screw with washer in both slots thru the holes left from the removal of the fender supports (see Figure 3). Secure the screws with washer and nut. Remove jack support.
  6. Using the 5/16" drill bit, mark (DO NOT drill thru!) the centers of each of the five holes. Drill the front and rear holes only using the 5/16" drill (see Figure 5).
  7. DO NOT drill the three center holes but using the awl, punch the three center holes NO LARGER than 3/16".
- NOTE: If there is bondo the area of the center three mounting holes, pre-drill these holes with the 1/8" drill bit, and enlarge them using the awl.*
8. Install three #14 truss head screw in the three center holes.
  9. Install one 1/4-20 X 3/4" truss head screw at each end of the Rockski with a large fender washer and nut on the back side.

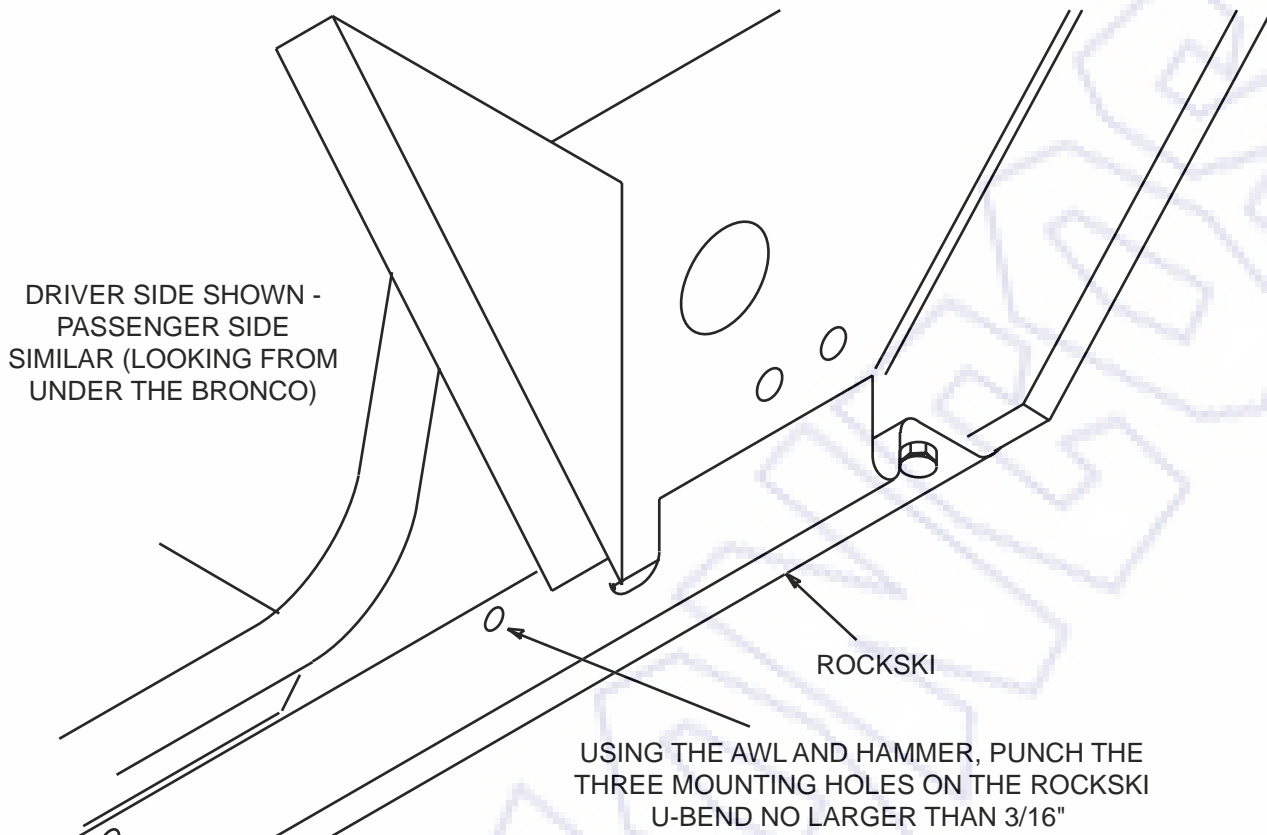

Figure 6

10. From under the Bronco, locate the three mounting holes on the Rockski u-bend. Mark the centers of the mounting using the 5/16" drill bit, DO NOT drill thru! Using the awl, punch the three holes NO LARGER than 3/16". Install #14 truss head screws. See Figure 6.

*NOTE: The auxiliary side tank on some Broncos may have to be removed to drill and secure the driver side Rockski.*

10. For Broncos with fender flares, reattach the fender flares. Center punch and drill using the 1/8" drill. Attach the fender flare using small button head screws with washers and nuts on the back side. (The fender flares can also be re-attached using pop rivets (not supplied).